

SM ECM-I2C Module

This module is specifically designed for 4-series electrochemical sensors to measure the concentration of a variety of gases including CO, H2S, NO2, HCL, NH3, SO2, etc. The module possesses the pluggable contacts and offers analogue voltage / I2C-BUS digital signal output. It also provides the function of onboard temperature measurement.

TECHNICAL PARAMETERS

- Input Voltage**

The module operating voltage is (+3.3 ~ +5.0) VDC. The absolute maximum value is +5.5 VDC.

- Power Consumption**

The operating current is less than 0.5 mA (electronics without sensor).

- Signal Offset**

+0.02 VDC (Can be adjusted according to customer's requirement).

- Sensors Available**

By selecting different resistor value of R4 and R5 as shown in Figure 1, users can achieve different biased voltage configuration. Therefore it works with most of 4-series (three-electrode type) electrochemical sensors listed in the table below.

R4	R5	Biased Voltage	Available Sensor
162k	5.6k	200 mV	HCL
Open	5.6k	300 mV	ETO, NO, C2H3CL
160k	68k	-600 mV	O2
162k	18k	0 mV	General
5.6k	162k	0 mV	(HF, NO2, CL2, CLO2, O3) negative signal
162k	2.9k	250 mV	C2H4

Figure 1 - Top Layer Layout

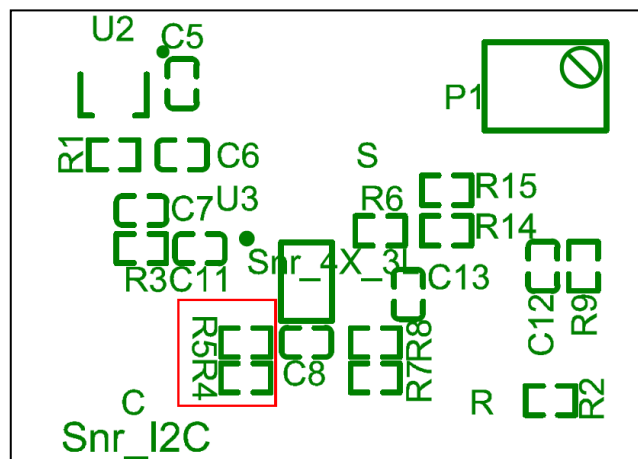

- **Measurement Ranges**

Please refer to related sensor datasheets available at www.semeatech.com.

- **Contacts**

8-pin contact, 2.54mm contact spacing.

- **Temperature Measurement**

The applicable measurement range is $-40 \sim +125^{\circ}\text{C}$. The analogue voltage output is 500 mV at 0°C , and it changes 10 mV per $^{\circ}\text{C}$ when temperature varies.

- **Voltage Output**

It is from 0.02 VDC to 4.7 VDC. Users can adjust the potentiometer to achieve the voltage output to match the required system parameters. It is recommended that the maximum output remains less than +4.5 VDC.

- **Digital Output**

Users can achieve the sensor digital output from the I2C-BUS communication mode. The module is assembled with Microchip's MCP3221A5T-E/OT that is a successive approximation A/D converter with a 12-bit resolution. Communication to the MCP3221 functions and can be activated by using a 2-wire, I2C compatible interface.

- Note:
- 1) MCP3221A5T-E/OT's device code is 1001 and address bits are 101;
 - 2) The reference voltage of MCP3221 is +3.0 VDC. If using the I2C-BUS output mode, please adjust the potentiometer to make the maximum voltage value at +3.0 VDC;
 - 3) There are no pull-up resistors of I2C-BUS on the module, users need to add the pull-up resistors on the system.

Figure 2 – Pin Configuration

PIN	DEFINITION
1	Digital output: I2C-BUS SCL signal
2	Digital output: I2C-BUS SDA signal
3	Analogue output: 0.02 ~ 4.5 VDC
4	GND
5	GND
6	GND
7	Temperature output
8	Input voltage: (+3.3 ~ +5.0) VDC

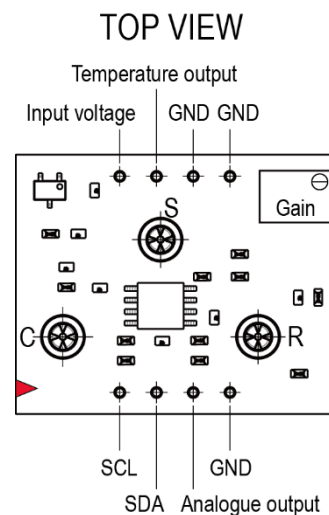

Figure 3 – Module Dimensions
(units in mm)

